

# **JONES<sup>®</sup> IF 15A**

**diesel hydraulic mobile crane  
with telescopic jib**

MAXIMUM LIFTING CAPACITY: 15 250 kg.

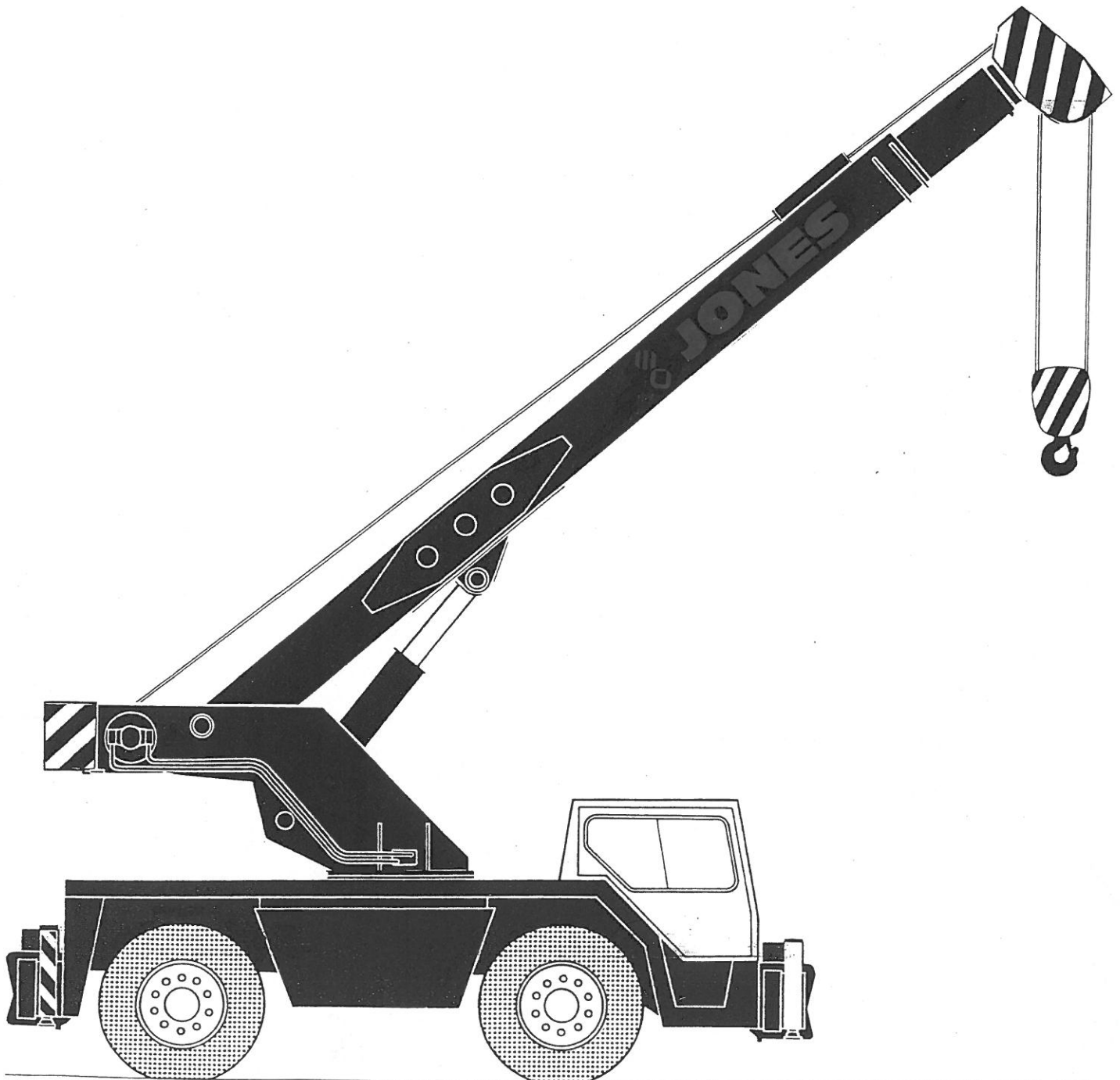

# JONES IF15A specification

## Power Unit

<b>Engine</b>	6 cylinder water cooled diesel engine developing 92,8kW (124bhp) at 2600 rpm.
<b>Transmission</b>	Allison fully automatic transmission with 4 forward and 1 reverse speed.

## Chassis

<b>Drive</b>	4 x 2 x 4
<b>Construction</b>	Purpose designed, fabricated from high tensile steel rolled channel and heavy steel plate with integral top cladding.
<b>Front axle</b>	Drive steer with centre bevel reduction and epicyclic hub reductions providing 11.4 ratio. Power assisted steering, protected if power source is lost.
<b>Rear axle</b>	Leaf spring mounted steering axle fitted with axle locks for crane duty. Tiller controlled power steering. Steering locks for road travel.
<b>Wheels and tyres</b>	12.00 x 20 x 20 ply, singles front and rear.
<b>Brakes</b>	Dual circuit air operated service brakes to all wheels with 'fail safe' spring operated emergency and parking brake to front wheels. The system incorporates a multi-circuit protection and complies with EEC requirements.
<b>Fuel tank</b>	Capacity 198 litres (44 gallons.)
<b>Outriggers</b>	Horizontal beam type with vertical jacking cylinders. Full hydraulic operation with controls in driver's cab.

## Crane superstructure

<b>Super-structure frame</b>	Welded high tensile steel structure on which is mounted the telescopic jib, hoist unit, hydraulic derricking cylinder and counterweight. The superstructure is capable of unlimited slewing in either direction and rotates on crossed roller bearing, which is sealed against the ingress of dust and water.
<b>Hydraulic pump</b>	Tandem gear pump driven from transmission power take-off. Manual pump disconnect operable from cab. First section, 147 litres/min (32,5 gallons/min), supplies hoist, derrick and telescope motions. Second section, 31 litres/min (7 gallons/min), supplies slew, outriggers and rear steer.
<b>Control valves</b>	Three bank unit controlling hoist, derrick and telescoping motions with additional single unit for slew motion, operated by control levers in driver's cab.
<b>Hoist motion</b>	Hydraulic motor driving through epicyclic gear reduction with counterbalance control on lowering, 'fail safe' hydromechanical disc brake, and machine grooved hoist drum suitable for multi-layer rope spooling.
<b>Derrick motion</b>	Double-acting hydraulic cylinder with integral pilot operated counterbalance safety check valve.
<b>Slew motion</b>	Hydraulic motor drive through epicyclic gear reduction to slew pinion. Counterbalance valve incorporated for smoothness and control.
<b>Jib telescoping motion</b>	Double-acting cylinder mounted within the jib structure, fitted with pilot operated counterbalance safety check valve.

## Dimensions

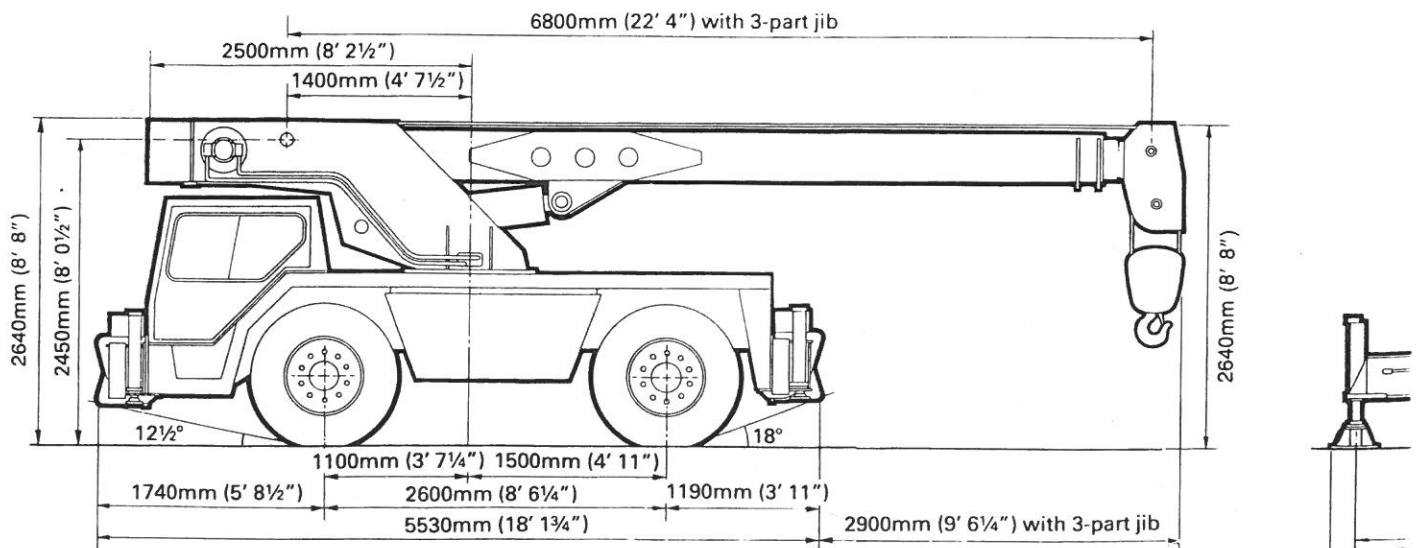

Overall length in travelling order 8430mm (27' 8") with 3-part jib

# JONES IF15A - IF15AT

## lifting capacities

Three section jib Lifting capacities in kilogrammes BS 1757:1986 and DIN 15019.2\*

Radius			Jib closed			Jib extended			Jib extended			* Jib fully extended with lattice extension			
			6,8m (22' 4")			6,8m to 11,64m (22' 4" - 38' 3")			11,64 to 16,5m (38' 3" - 54' 2")			23,0m (75' 6")		+stinger 27,9m (91' 6")	
			blocked 360°	free-on-wheels 360° over front		blocked 360°	free-on-wheels 360° over front		blocked 360°	free-on-wheels 360° over front		∠°	blocked 360°	∠°	blocked 360°
m	ft	in	kg	kg	kg	kg	kg	kg	kg	kg		kg		kg	
2,50	8	2	15 250	7 500	8 000										
2,75	9	0	15 250	7 000	7 750	15 250	7 000	7 750							
3,00	9	10	15 250	6 500	7 400	13 200	6 500	7 400	6 200						
3,25	10	7	13 500	6 000	6 900	12 000	6 000	6 900	6 200						
3,50	11	6	12 400	5 450	6 300	11 000 †	5 450 †	6 300 †	6 200	5 000	6 300				
3,75	12	3	11 000	4 850	5 600	10 150	4 850	5 600	6 200	4 700	5 600				
4,00	13	1	10 000	4 400	5 100	9 300	4 400	5 100	6 200	4 400	5 100				
4,50	14	9	8 400	3 650	4 250	8 150	3 650	4 250	6 000 †	3 650 †	4 250 †				
5,00	16	5	7 250	3 100	3 600	7 250	3 100	3 600	5 700	3 100	3 600				
5,50	18	0				6 600	2 650	3 100	5 400	2 650	3 100				
6,00	19	8				6 000	2 300	2 700	5 150	2 300	2 700				
7,00	23	0				5 000	1 750	2 050	4 600	1 750	2 050	70	2 300 at 7,5MR		
8,00	26	3				4 150	1 300	1 600	4 150	1 300	1 600	69	2 140		
9,00	29	6				3 500	1 000	1 250	3 500	1 000	1 250	66	1 870		
10,00	32	10				2 900	750	950	2 900	750	950	63	1 650	69 1 000	
11,00	36	1							2 400	600	750	60	1 470	66 870	
12,00	39	4							2 000	450	600	57	1 360	64 750	
13,00	42	8							1 700		450	54	1 270	61 670	
14,00	45	11							1 500			51	1 200	59 600	
15,00	49	3							1 300			48	1 120	57 560	
16,00	52	6										44	1 080	55 520	
17,00	55	9										40	1 020	51 500	
18,00	59	1										36	1 000	49 480	
19,00	62	4												46 460	
20,00	65	7												44 440	
21,00	68	11												41 420	
22,00	72	2												37 400	

\*1. Specified capacities relate ONLY to the machine as originally manufactured and equipped and used in accordance with CP.3010 "Safe use of cranes". Any modification invalidates this information.

2. The capacities are in accordance with Clause 9.1.3c "STABILITY" of BS1757:1986 "Power Driven Mobile Cranes" with wind forces to tables 5A and 6A of BS2573, and also comply to DIN 15019.2.

3. Capacities are the gross maximum loads which may be freely suspended from the jib head with the crane standing level on a firm supporting surface.

4. When determining the suspended load, the weights of hook block, slings and any lifting attachments must be added to the weight to be lifted.

Six fall block: 170kg. Single fall block: 32kg.

5. Radius is measured with the load suspended.

6. Capacities free-on-wheels depend on correct tyre pressure, type, capacity and condition.

7. Capacities shown above the bold line are based on factors other than stability. For this reason stability must not be relied upon to indicate capacity.

8. Under normal circumstances it is permissible to attempt to telescope the jib in or out with a load suspended, providing the load/radius is within the capacity shown in the duty chart at all times.

9. Capacities over the front apply only within 5° either side of the crane centre line.

10. Suspended loads may be transported at speeds up to 5 km/h (3 m.p.h.). Loads should be carried over the front of the crane whenever possible. Axle locks must be engaged before lifting free-on-wheels except over the front within 5° either side of the crane centre line.

11. This crane is not approved for use on pile driving or extraction operations.

12. The jib should not be operated even without a load, at an, combination of length or radius where there is no lifting capacity indicated on the chart. To do so may result in loss of machine stability.

# JONES

JONES CRANES PARTS

Unit 3, Firland Estate, Albourne,  
West Sussex, BN6 9JJ, England

# JONES IF15A - IF15AT

## lifting capacities

Three section jib Lifting capacities in kilogrammes BS 1757:1986 and DIN 15019.2\*

Radius			Jib closed			Jib extended			Jib extended			* Jib fully extended with lattice extension			
			6,8m (22' 4")			6,8m to 11,64m (22' 4" - 38' 3")			11,64 to 16,5m (38' 3" - 54' 2")			23,0m (75' 6")		+stinger 27,9m (91' 6")	
			blocked 360°	free-on-wheels 360° over front		blocked 360°	free-on-wheels 360° over front		blocked 360°	free-on-wheels 360° over front		∠°	blocked 360°	∠°	blocked 360°
m	ft	in	kg	kg	kg	kg	kg	kg	kg	kg		kg		kg	
2,50	8	2	15 250	7 500	8 000										
2,75	9	0	15 250	7 000	7 750	15 250	7 000	7 750							
3,00	9	10	15 250	6 500	7 400	13 200	6 500	7 400	6 200						
3,25	10	7	13 500	6 000	6 900	12 000	6 000	6 900	6 200						
3,50	11	6	12 400	5 450	6 300	11 000 †	5 450 †	6 300 †	6 200	5 000	6 300				
3,75	12	3	11 000	4 850	5 600	10 150	4 850	5 600	6 200	4 700	5 600				
4,00	13	1	10 000	4 400	5 100	9 300	4 400	5 100	6 200	4 400	5 100				
4,50	14	9	8 400	3 650	4 250	8 150	3 650	4 250	6 000 †	3 650 †	4 250 †				
5,00	16	5	7 250	3 100	3 600	7 250	3 100	3 600	5 700	3 100	3 600				
5,50	18	0				6 600	2 650	3 100	5 400	2 650	3 100				
6,00	19	8				6 000	2 300	2 700	5 150	2 300	2 700				
7,00	23	0				5 000	1 750	2 050	4 600	1 750	2 050	70	2 300 at 7,5MR		
8,00	26	3				4 150	1 300	1 600	4 150	1 300	1 600	69	2 140		
9,00	29	6				3 500	1 000	1 250	3 500	1 000	1 250	66	1 870		
10,00	32	10				2 900	750	950	2 900	750	950	63	1 650	69 1 000	
11,00	36	1							2 400	600	750	60	1 470	66 870	
12,00	39	4							2 000	450	600	57	1 360	64 750	
13,00	42	8							1 700		450	54	1 270	61 670	
14,00	45	11							1 500			51	1 200	59 600	
15,00	49	3							1 300			48	1 120	57 560	
16,00	52	6										44	1 080	55 520	
17,00	55	9										40	1 020	51 500	
18,00	59	1										36	1 000	49 480	
19,00	62	4												46 460	
20,00	65	7												44 440	
21,00	68	11												41 420	
22,00	72	2												37 400	

\*1. Specified capacities relate ONLY to the machine as originally manufactured and equipped and used in accordance with CP.3010 "Safe use of cranes". Any modification invalidates this information.

2. The capacities are in accordance with Clause 9.1.3c "STABILITY" of BS1757:1986 "Power Driven Mobile Cranes" with wind forces to tables 5A and 6A of BS2573, and also comply to DIN 15019.2.

3. Capacities are the gross maximum loads which may be freely suspended from the jib head with the crane standing level on a firm supporting surface.

4. When determining the suspended load, the weights of hook block, slings and any lifting attachments must be added to the weight to be lifted.

Six fall block: 170kg. Single fall block: 32kg.

5. Radius is measured with the load suspended.

6. Capacities free-on-wheels depend on correct tyre pressure, type, capacity and condition.

7. Capacities shown above the bold line are based on factors other than stability. For this reason stability must not be relied upon to indicate capacity.

8. Under normal circumstances it is permissible to attempt to telescope the jib in or out with a load suspended, providing the load/radius is within the capacity shown in the duty chart at all times.

9. Capacities over the front apply only within 5° either side of the crane centre line.

10. Suspended loads may be transported at speeds up to 5 km/h (3 m.p.h.). Loads should be carried over the front of the crane whenever possible. Axle locks must be engaged before lifting free-on-wheels except over the front within 5° either side of the crane centre line.

11. This crane is not approved for use on pile driving or extraction operations.

12. The jib should not be operated even without a load, at an combination of length or radius where there is no lifting capacity indicated on the chart. To do so may result in loss of machine stability.

**JONES** CRANES  
JONES CRANES PARTS

Unit 3, Firland Estate, Albourne,  
West Sussex, BN6 9JJ, England

## Jib Equipment

- Main jib** Basic jib 6,8m (22' 4") extending to 16,5m (54' 2"). Three part box section construction comprising:- base section and two fully powered sections operated by a two-cylinder double-acting unit within the jib structure.
- Lattice extension jib (optional)** 6,5m (21' 4") long, with stinger extending to 11,4m (37' 5"), stowed alongside the main jib for road travel.
- Hoist rope** 13mm diameter, 125m (410') long.
- Hook block** Three sheave block for maximum duty.

## Electrical

- System** 12-volt negative earth.
- Equipment** Alternator for starting and charging circuits, 12-volt 125 A/hr battery, full road lighting to EEC requirements.

## Driver's cab

- Construction** Large automotive type cab with easy access through side doors. Fully enclosed steel structure with maximum all-round vision through safety glass windows.
- Fittings** Upholstered adjustable driver's seat, upholstered passenger's seat, cab heater/demister, front screen wiper, internal light, rear view mirrors and front screen washers. Reversible passenger's seat with additional controls.
- Instruments** Speedometer, odometer, fuel gauges: engine oil, transmission oil and coolant water temperature gauges: engine oil and air pressure gauges.

Warning lights for battery charging, low air pressure, direction indicators, rear fog lights, hazard warning lights, power take-off and axle lock engagement.

## Controls

Normal automotive road controls. Crane controls for all functions are mounted in the driver's cab.

## Safety equipment

- Standard** Overhoist cut-out. Pressure relief valve in main hydraulic circuit. Integral pilot operated safety check valves fitted to derricking, telescoping and jacking hydraulic cylinders.
- Optional** Audible and visual rated capacity indicator. Overhoist/overload cut-outs.

## Paint finish

High gloss finish – yellow cab, black super-structure, black chassis.

## Axle loads and total weight

with crane in normal travelling order.

	3-piece jib	
	kg	lb
Front axle	9340	20594
Rear axle	6200	13671
Total weight	15540	34265

To meet manufacturing conditions and developments in design, the illustrations and information in this publication are subject to modification without notice. The information contained in this specification must not be incorporated into any contractual documentation without prior agreement of GCM 600 Limited.

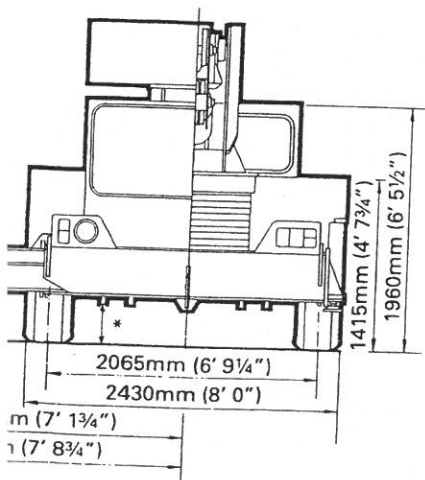

Minimum ground clearance 280mm (11")

## Performance data

Hoist	Laden	Unladen
6 falls	8,8m/min (29ft/min)	10,2m/min (33ft/min)
Single line	52,7m/min (173ft/min)	60,6m/min (199ft/min)
Line pull	2750kg	

**Derrick up or down between 70° and horizontal:** 18,3 seconds.

**Jib extension or retraction:** 36,6 seconds with 3-piece jib.

**Slew:** up to 3 r.p.m.

**Maximum negotiable gradient:** 25% (1:4) unladen.

**Turning circle:** 10,0m (32' 9") between kerbs.

**Road speed:** 46km/h (28,3 m.p.h.).

**Carry deck capacity:** 6 tonnes maximum.

## Jib Equipment

- Main jib** Basic jib 6,8m (22' 4") extending to 16,5m (54' 2"). Three part box section construction comprising:- base section and two fully powered sections operated by a two-cylinder double-acting unit within the jib structure.
- Lattice extension jib (optional)** 6,5m (21' 4") long, with stinger extending to 11,4m (37' 5"), stowed alongside the main jib for road travel.
- Hoist rope** 13mm diameter, 125m (410') long.
- Hook block** Three sheave block for maximum duty.

## Electrical

- System** 12-volt negative earth.
- Equipment** Alternator for starting and charging circuits, 12-volt 125 A/hr battery, full road lighting to EEC requirements.

## Driver's cab

- Construction** Large automotive type cab with easy access through side doors. Fully enclosed steel structure with maximum all-round vision through safety glass windows.
- Fittings** Upholstered adjustable driver's seat, upholstered passenger's seat, cab heater/demister, front screen wiper, internal light, rear view mirrors and front screen washers. Reversible passenger's seat with additional controls.
- Instruments** Speedometer, odometer, fuel gauges: engine oil, transmission oil and coolant water temperature gauges: engine oil and air pressure gauges.

Warning lights for battery charging, low air pressure, direction indicators, rear fog lights, hazard warning lights, power take-off and axle lock engagement.

## Controls

Normal automotive road controls. Crane controls for all functions are mounted in the driver's cab.

## Safety equipment

- Standard** Overhoist cut-out. Pressure relief valve in main hydraulic circuit. Integral pilot operated safety check valves fitted to derricking, telescoping and jacking hydraulic cylinders.
- Optional** Audible and visual rated capacity indicator. Overhoist/overload cut-outs.

## Paint finish

High gloss finish – yellow cab, black super-structure, black chassis.

## Axle loads and total weight

with crane in normal travelling order.

	3-piece jib	
	kg	lb
Front axle	9340	20594
Rear axle	6200	13671
Total weight	15540	34265

To meet manufacturing conditions and developments in design, the illustrations and information in this publication are subject to modification without notice. The information contained in this specification must not be incorporated into any contractual documentation without prior agreement of GCM 600 Limited.

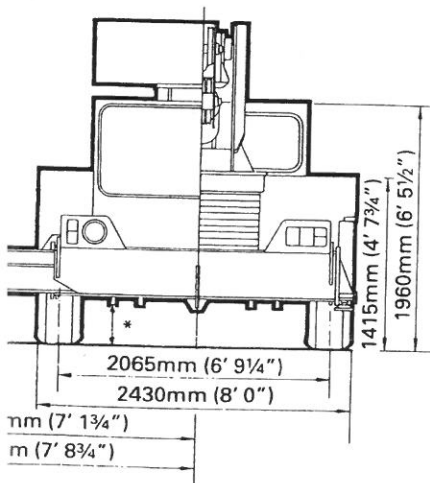

num ground clearance 280mm (11")

## Performance data

Hoist	Laden	Unladen
6 falls	8,8m/min (29ft/min)	10,2m/min (33ft/min)
Single line	52,7m/min (173ft/min)	60,6m/min (199ft/min)
Line pull	2750kg	

**Derrick up or down between 70° and horizontal:** 18,3 seconds.

**Jib extension or retraction:** 36,6 seconds with 3-piece jib.

**Slew:** up to 3 r.p.m.

**Maximum negotiable gradient:** 25% (1:4) unladen.

**Turning circle:** 10,0m (32' 9") between kerbs.

**Road speed:** 46km/h (28,3 m.p.h.).

**Carry deck capacity:** 6 tonnes maximum.